

AD Access

Fume Extraction System - Advantage Range

Datasheet

Technical Specification and Product Information

A compact fume extraction system for light-duty laser applications.

The AD Access is a compact fume extraction system for light-duty laser applications. This affordable system helps to improve both the workplace environment and product quality.

FEATURES

- Low noise levels
- Small footprint
- Long-life, low-cost replacement filters

Approvals: UKCA and CE | cUL | UL*



TECHNICAL SPECIFICATION

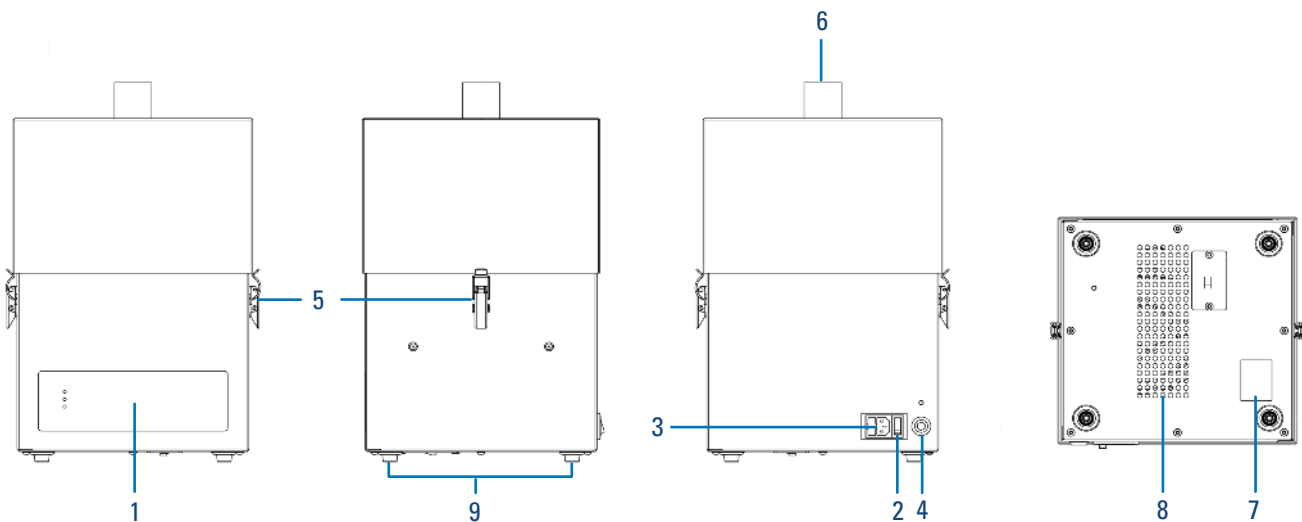

- | | | |
|----------------------|---|-------------------------|
| 1. Control panel | 4. Signal/interface cable | 7. Exhaust outlet |
| 2. On/off switch | 5. Filter compartment latches | 8. Blower cooling inlet |
| 3. Power cable inlet | 6. Hose inlet connection - 2.0" (50 mm) | 9. Feet |

TECHNICAL DATA

Voltage	Airflow		Pressure	Dimensions (H x W x D)		Weight (+/- 5%)		Noise level**	Frequency	Full load current
	cfm	m ³ /hr		in	mm	lbs	kg			
115	106	180	30	19.9 x 13.2 x 12.4	505 x 335 x 315	53	24	< 56	50/60	1.5
230								< 61		0.9

AIRFLOW

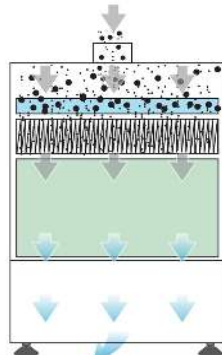
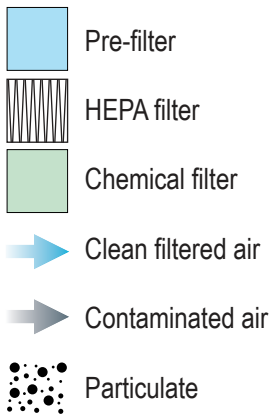

PART NUMBERS - SYSTEM

Description	Part number
Powder-coated, 230 V No options	1U30761512-1313
Powder-coated, 230 V 24 V S/S, SOK and O/R	1U4680761512-1313
Powder-coated, 115 V 24 V S/S and SOK	1U630760512-1313
Powder-coated, 115 V 24 V S/S, SOK, USA plug	1U4660760512-2
Powder-coated, 230 V No options, USA plug	1U4650761512

FILTER SPECIFICATIONS

Model	Surface media area (approx)		Filter efficiency
	ft ²	m ²	
DeepPleat pre-filter	18.7	1.7	ePM1 70%
Combined filter (HEPA)	21.5	2.0	99.99% @ 0.3 microns

Model	Activated carbon volume	
	lbs	kg
Combined filter (gas)	15.4	7

PART NUMBERS - FILTERS

DeepPleat pre-filter	Combined filter
1UA1030153	1UA1030154

CUSTOMIZATIONS

Options

Power cables
Remote stop/start signal (S/S)
System OK signal (SOK)
Override (O/R)
VOC sensor

Power cables

Type B
Type E
Type G

Cabinet construction

Powder-coated mild steel (RAL7016)

*UL: Tested to UL standards, but testing may be provided by alternate nationally recognized test laboratories. Certain product configurations may affect the UL certification. Please speak to your sales representative.

** Noise level: At typical operating speed.

Datasheet correct at time of publishing. Where applicable, the carbon used in Donaldson BOFA systems is capable of removing a wide range of VOCs, however it is the responsibility of the user to ensure the carbon is suitable for their application. For specific applications, please contact us for details.

Important Notice

Many factors beyond the control of Donaldson can affect the use and performance of Donaldson products in a particular application, including the conditions under which the product is used. Since these factors are uniquely within the user's knowledge and control, it is essential the user evaluate the products to determine whether the product is fit for the particular purpose and suitable for the user's application. All products, product specifications, availability and data are subject to change without notice, and may vary by region or country.



Approvals: REACH and RoHS. See individual product technical data for specific accreditations.

FS 643451
ISO 9001



Donaldson BOFA

UK & ROW
Tel. +44 (0) 1202 699 444
Email. bofasales@donaldson.com
Web. donaldsonbofa.com

Germany
Email. bofavertrieb@donaldson.com

USA
Tel. +1 (618) 205 5007
Email. bofasalesus@donaldson.com

ENG (December 2024) Donaldson BOFA AD Access Datasheet. ©2011-2024 Donaldson Company, Inc. Donaldson, Torit, Dalamatic, Delta P, Delta P Plus, Downflo, Dura-Life, Easy Duct, PowerCore, Synteq XP, Ultra-Web, Unimaster and the color blue are marks of Donaldson Company, Inc. All other marks belong to their respective owners.