



AD Oracle Pro OS AD Oracle Pro OS Connect

Fume Extraction System

User Manual

Installation, Operation, and Service Information



This manual contains specific precautions related to worker safety. The hazard alert image denotes safety related instructions and warnings in this manual. DO NOT install, operate, or perform maintenance on this system until you have read and understood the instructions, precautions and warnings contained within this manual.

English
Original instructions

UM-AD-ORACLE PRO OS AND CONNECT-BOFA-US
Revision 2.5

Donaldson BOFA Technical Service

If a problem arises with your system, please refer to the troubleshooting section of this manual. If the problem is still not resolved, please:

- Visit our website at donaldsonbofa.com for online help.
- Or contact the helpline:
 - ROW: +44 (0) 1202 699 444 (Mon-Fri 9am-5pm GMT)
 - US: +1 (618) 205 5007 (Mon-Fri 9am-5pm CST)
- Email:
 - ROW: bofatechnical@donaldson.com
 - US: bofatechnicalus@donaldson.com

Serial Number

For future reference, fill in your system details in the space provided. The serial number is on the rating label located on the side/rear of the system.

Table of Contents

1	Overview.....	5
1.1.	Front view of AD Oracle Pro OS Connect	5
1.2.	Rear view of AD Oracle Pro OS Connect	6
1.3.	Overview of control panel	7
2	Safety information	8
2.1.	Important safety notes	8
2.2.	Warning and information labels	9
2.3.	Fire risk warning	10
3	Before installation	11
3.1.	Packaging removal and system placement	11
4	Installation	13
4.1.	Fume capture methods	13
4.2.	General guidelines for a successful installation	13
4.3.	Flexible arm and nozzle extraction	13
4.4.	Moving products	13
4.5.	Enclosures	13
4.6.	Cabinets	14
4.7.	Connection to extraction system	14
4.8.	Exhausting filtered air outside	14
4.8.1.	Exhaust box - vent to air to spigot	14
4.8.2.	Exhaust box - spigot to vent to air	14
4.9.	Connectivity (optional)	15
4.10.	Connection to power supply	15
4.11.	Remote stop/start signal (standard)	16
4.12.	System OK signal (standard)	16
5	Operation	17
5.1.	Turning extraction system on	17
5.2.	Power on cycle	17
5.3.	Accessing the menu and first time operation	17
5.4.	Settings	17
5.4.1.	Changing the display systems	18
5.4.2.	Enabling the autorun feature	18
5.4.3.	Changing the language	18
5.5.	Information	18
5.6.	Support	19
5.7.	Brightness	19
5.8.	Functional test	19
5.9.	Run control	20
5.9.1.	Off state	20
5.9.2.	Running state	20
5.10.	Setting the desired airflow	21
5.10.1.	To set the airflow	21
5.11.	System status of filters and blower	21
5.11.1.	Filter blockage level indication	21

5.11.2.	Filter not installed correctly warning	22
5.11.3.	Inlet status	22
5.11.4.	Blower diagnostics	22
5.11.5.	Filter status	23
5.11.6.	System temperature	23
6	Maintenance	24
6.1.	Maintenance UK	24
6.2.	Maintenance general	24
6.2.1.	Cleaning the extraction system	24
6.3.	Replacing filters	24
6.3.1.	Pre-filter replacement	25
6.3.2.	Combined filter replacement	25
7	System display	27
7.1.	USB connectivity	27
7.1.1.	USB lock	27
7.1.2.	Upload/download	27
8	Troubleshooting	29
8.1.	Fault indication	29
8.2.	System alarms	29
8.2.1.	Thermal	29
8.2.2.	Hose blocked	30
8.2.3.	Combined filter not fitted correctly	30
8.2.4.	Pro OS board overheating	30
8.2.5.	System fault	30
8.2.6.	VOC sensor	30
8.2.7.	Auto adjust	30
8.3.	Blower fault	31
9	Replacement parts	32
9.1.	Consumable spares	32
9.2.	Maintenance protocol	32
9.3.	Filter disposal	32
10	System specifications	33
11	Contact information	34
12	Inspection record	35

1 Overview

1.1 Front view of AD Oracle Pro OS Connect

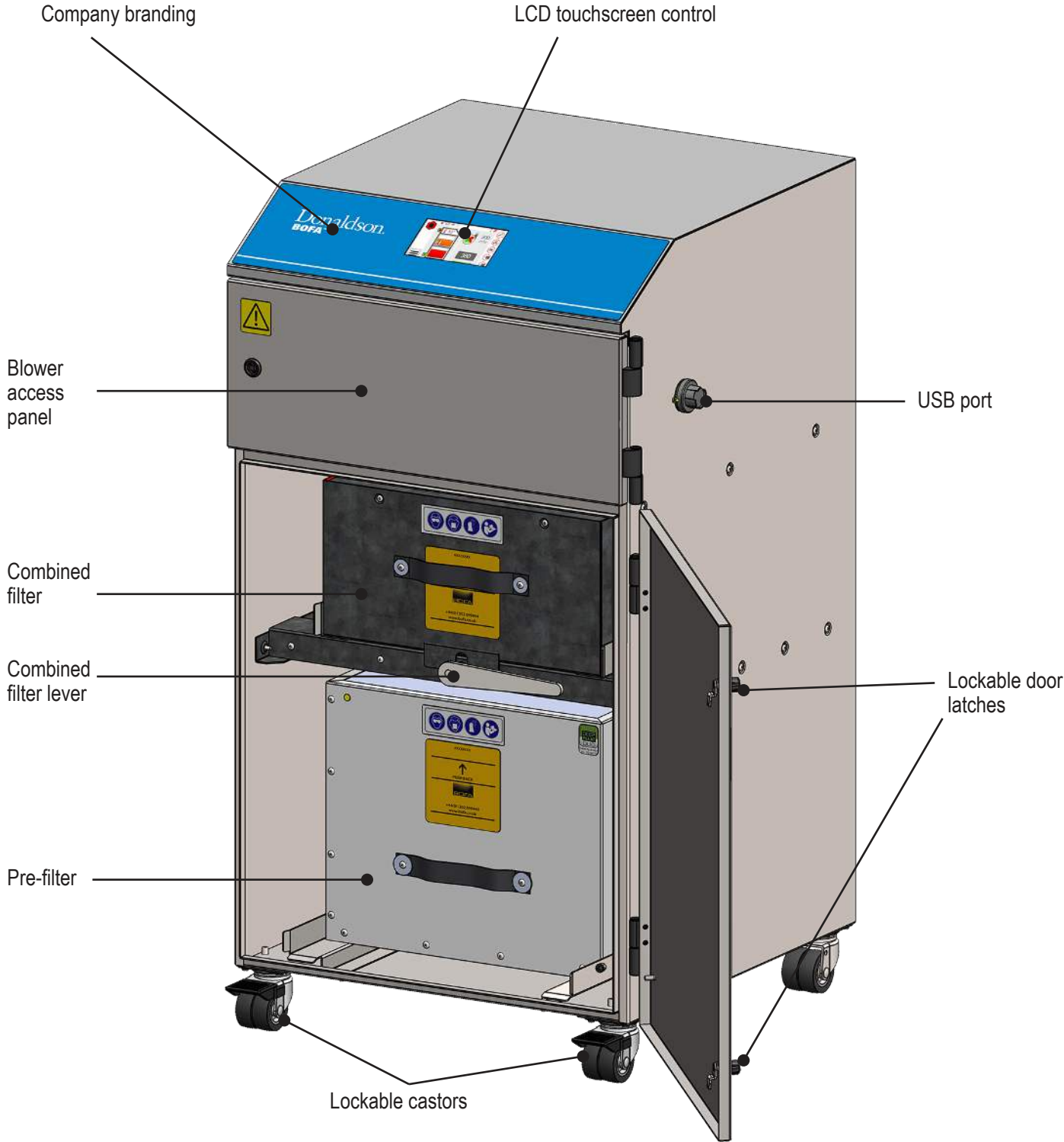

1.2. Rear view of AD Oracle Pro OS Connect

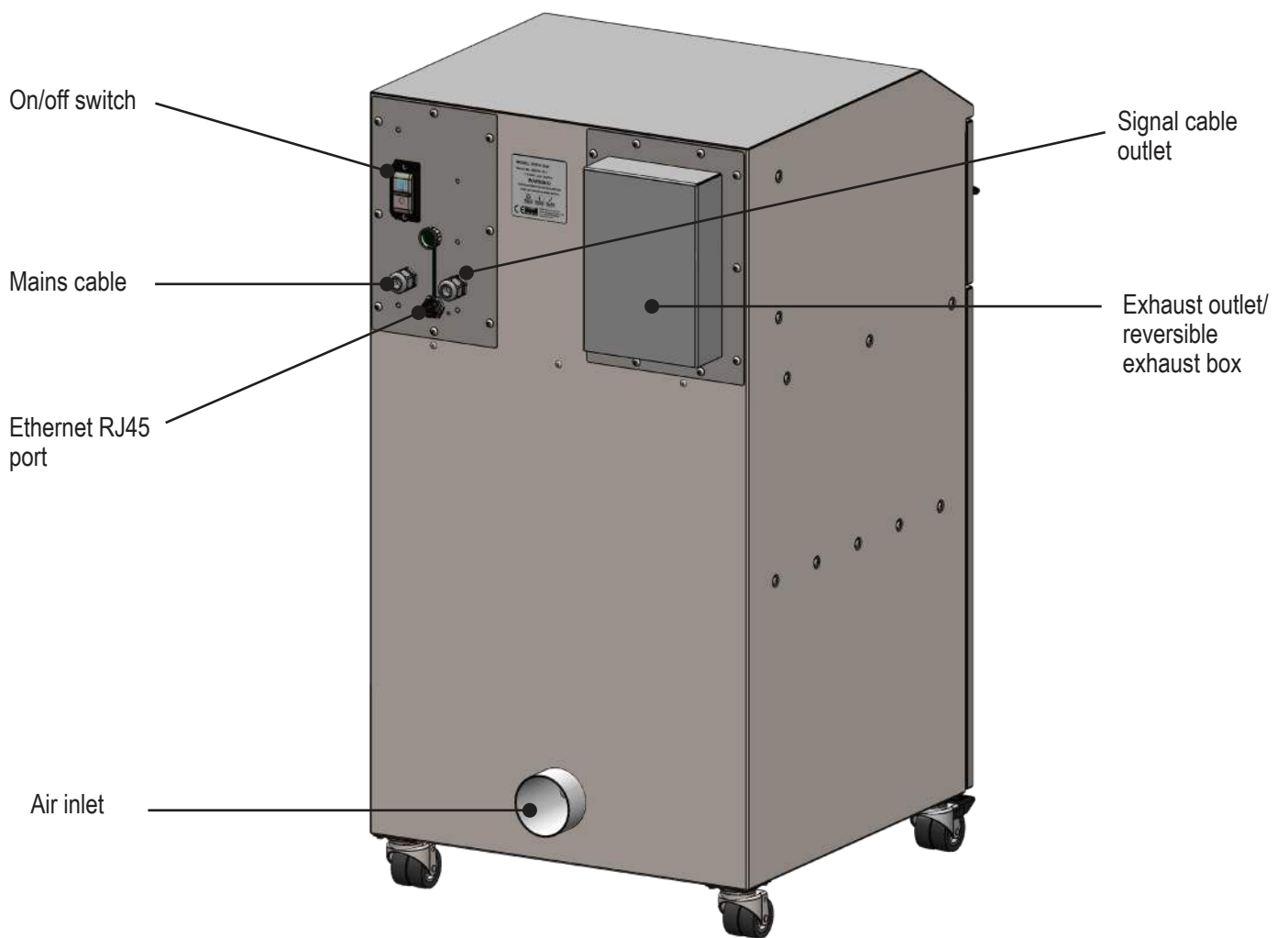

1.3. Overview of control panel

The diagram below shows an overview of LCD touchscreen features.

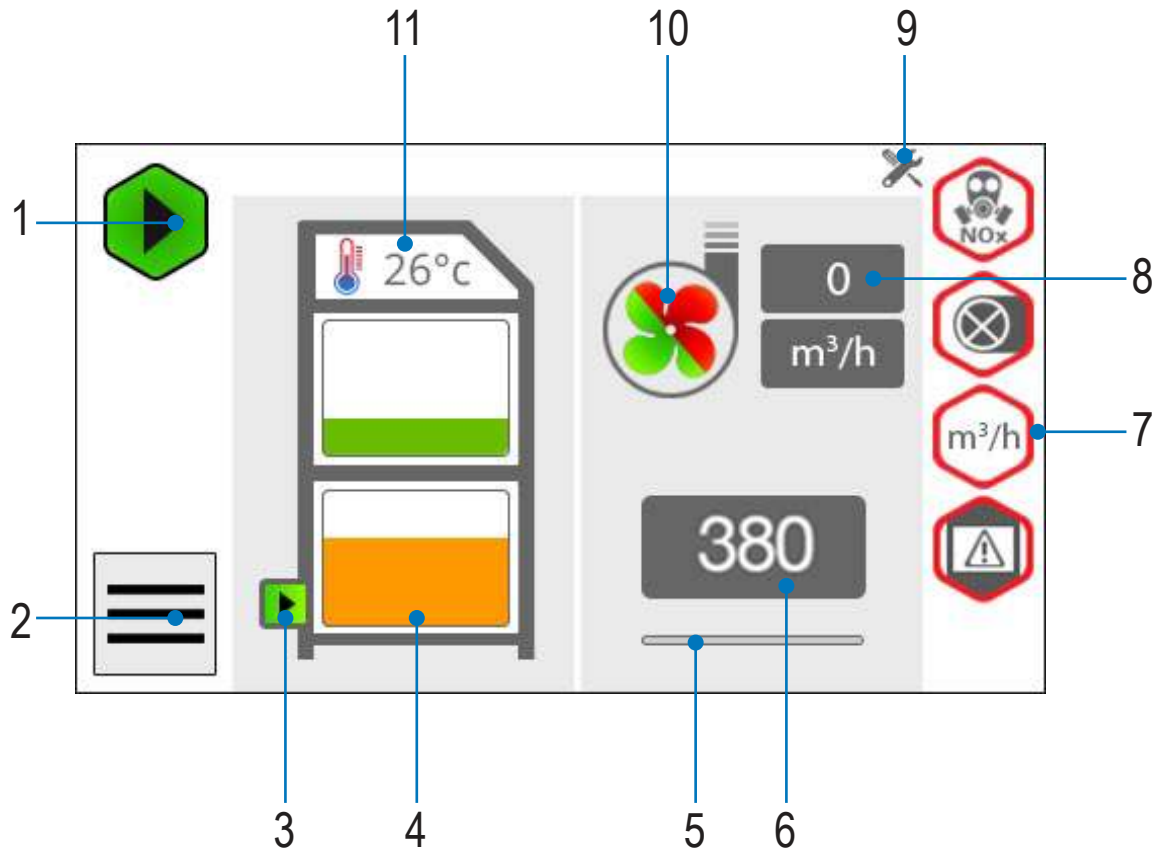





Number	Feature	Function	Navigates to:
1.	Run control	Allows the operator to stop/start the extraction.	
2.	Menu		Menu screen
3.	System indication	Visual indication of inlet status.	System information screen
4.	Filter indication	Visual indication of filter condition.	Relevant filter data screen
5.	Airflow level indication	Visual indication of flow setpoint relative to maximum setpoint.	
6.	Airflow setpoint	Visual indication of airflow setpoint.	Airflow setting screen
7.	Alarm notifications bar	Visual indication of alarm states. Shows activated alarms.	Alarms screen
8.	Actual flow	Visual indication of system flow. Configurable to CFM or m³/h.	
9.	Service indication	Always displayed. Links user to the support screen.	
10.	Blower status	Visual indication of blower status.	Blower diagnostics screen
11.	Temperature status	Visual indication of internal system temperature. Configurable to °F or °C.	

2 Safety information

2.1 Important safety notes

Concerning symbols used on the extraction system and referred to within this manual.

Symbol	Meaning	
	DANGER	Refers to an immediately impending danger. If the danger is not avoided, it could result in death or severe (crippling) injury. Please consult the manual when this symbol is displayed.
	WARNING	Refers to a possibly dangerous situation. If not avoided, it could result in death or severe injury. Please consult the manual when this symbol is displayed.
	CAUTION	Refers to a possibly harmful situation. If not avoided, damage could be caused to the product or something in its environment.
	IMPORTANT (refer to manual)	Refers to handling tip and other particularly useful information. This does not signify a dangerous or harmful situation. Refer to manual when this symbol is displayed.

EU Declaration

The system has been designed to meet the essential health and safety requirements of the Machinery Directive 2006/42/EC, Low Voltage Directive 2014/35/EC, and the EMC Directive 2014/30/EU. For the full DOC and further information please contact the technical team:

- US: bofatechnicalus@donaldson.com
- ROW: bofatechnical@donaldson.com

Electrical safety

The system has been designed to meet the essential health and safety requirements of the Low Voltage Directive 2014/35/EC. The requirements of the EMC Directive 2014/30/EU are also met.

Warning

When working with the blower housing open, live 230/115 volt mains components are accessible. Ensure that the rules and regulations for work on live components are always observed.

Important

To reduce the risk of fire, electric shock, or injury:

1. Always isolate the system from the mains power supply before removing the blower access panel.
2. Use only as described in this manual.
3. Connect the system to a properly grounded outlet.

Dangers to eyes, breathing, and skin

Once used, the filters within the extraction system may contain a mixture of particulates, some of which may be sub-micron size. When the used filters are moved, it may agitate some of this particulate, which could get into the breathing zone and eyes of the operative.

Additionally, depending on the materials being processed, the particulate may be an irritant to the skin.

This system should not be used on processes with sparks of flammable materials or with explosive dusts and gases, without implementation of additional precautions.

	CAUTION	When changing used filters, always wear a mask, safety shoes, goggles, and gloves.
---	---------	--

Carbon selection





Please note that the media within the gas filter fitted in the extraction system is capable of adsorbing a wide range of organic compounds. However, it is the responsibility of the user to ensure it is suitable for the particular application it is being used on.

Intended use

This equipment has been designed to extract and filter fume from a variety of applications. However, it is the user's responsibility to ensure the equipment is installed correctly and is suitable for the application. This extraction system must not be used on wet applications or acidic fumes.

2.2. Warning and information labels

The following listing details labels used on your system.

Symbol	Meaning	
	GOGGLES, GLOVES AND MASK	This appears on filters, indicating that goggles, gloves, and masks should be worn while handling used filters.
	DO NOT COVER	Do not cover any louvers or holes on panels adjacent to the label.
	ELECTRICAL DANGER	Removal of panels with this label attached will allow access to potentially live components.
	WARNING	Power should be isolated before the panel with this label attached is opened/removed.

PLEASE NOTE: If the equipment is used in a manner not specified by the manufacturer, the protection provided by the equipment may be compromised.

2.3. Fire risk warning

In the very rare event that a burning ember or spark is drawn into the fume extraction system, it may be possible that the filters will ignite. Whilst any resultant fire would typically be retained within the fume extraction system, the damage to the extraction system could be significant.

It is therefore essential to minimize the possibility of this occurring by undertaking an appropriate risk assessment to determine:

- a). Whether additional fire protection equipment should be installed.
- b). Appropriate maintenance procedures to prevent the risk of build-up of debris which could potentially combust.

This extraction system should not be used on processes where sparks could occur, with explosive dusts and gases, or with particulates that can be pyrophoric (can spontaneously ignite), without implementation of additional precautions. It is essential that nozzles or other extraction/fume capture devices and hoses/pipework are cleaned regularly to prevent the build-up of potentially ignitable debris.

3 Before installation

3.1. Packaging removal and system placement

Before installation, check the extraction system for damage.

All packaging must be removed before the system is connected to the power supply.

Please read all instructions in this manual before using this extraction system.

1. Move the system to the location where it is going to be installed and remove the outer packaging.

This system should be installed in a well-ventilated area.

2. Open the front door and remove the transit foam and straps from system. Ensure that 20" (500 mm) space is available around any vented panels on the system to ensure adequate airflow.

3. With the system in position, lock the two front castors.

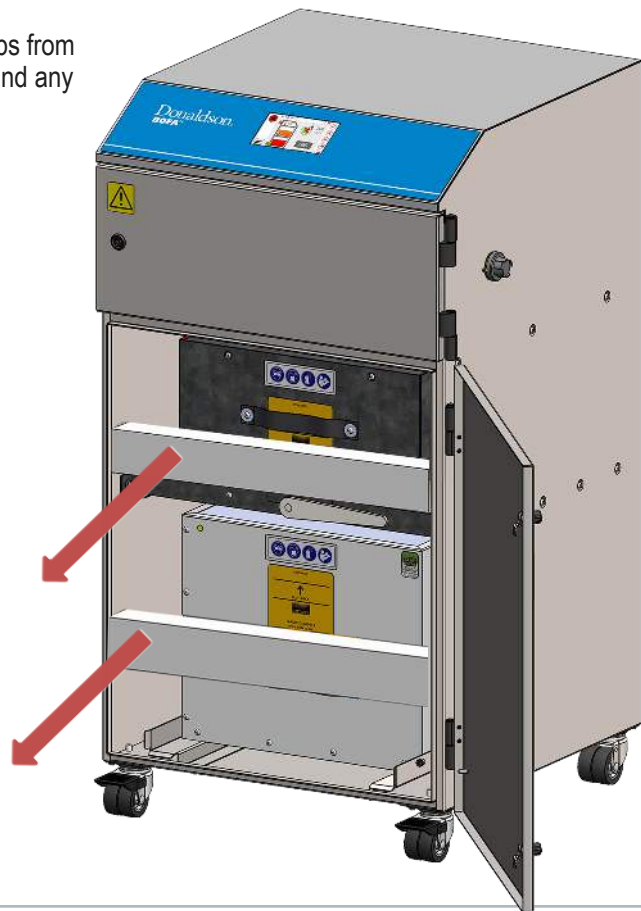
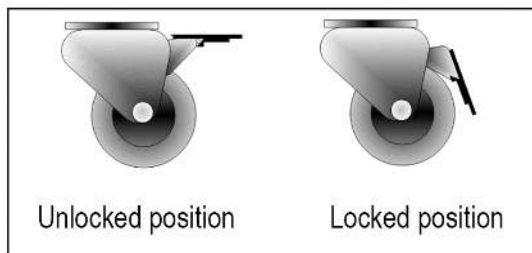

	CAUTION	Due to the weight of the extraction system, suitable lifting equipment should be used and appropriate safety precautions taken (see system specification section for product weight detail).
--	---------	--

	CAUTION	Do not block or cover the cooling vents on the extraction system, as this severely restricts airflow and may cause damage to the system.
--	---------	--

	CAUTION	Under no circumstances should the exhaust outlet/s be covered as this will restrict the airflow and cause overheating.
--	---------	--

4. Check the filters are located in their correct position before closing the door and securing the door latches.

Note: An alarm will activate if the combined filter has not been fitted correctly.

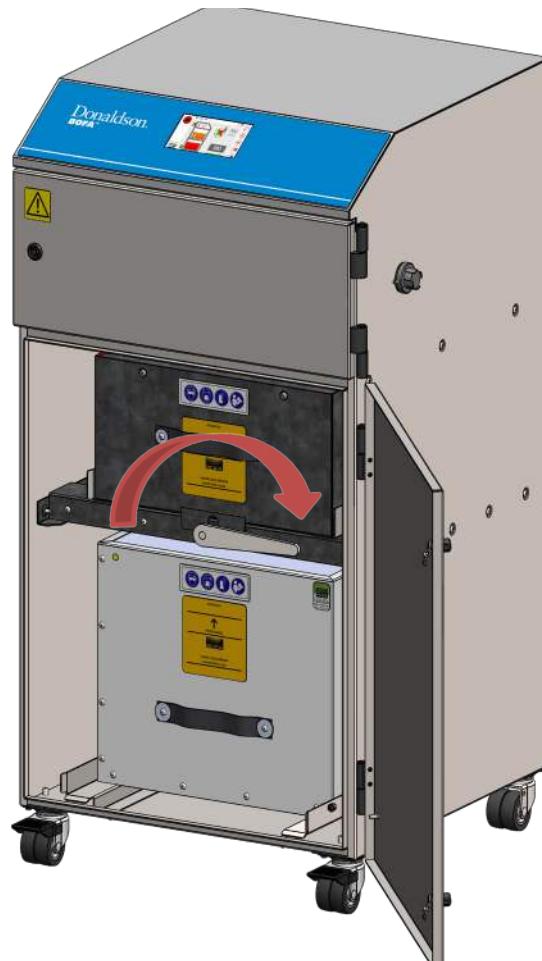

4 Installation

The system has been designed to remove and filter fume containing potentially hazardous particulate and gases generated during manufacturing processes. Such hazardous substances are captured within a multi-stage filtration system after which the cleaned air is returned to the workplace.

4.1. Fume capture methods

The fume is normally captured by 1 of 3 methods.

- Flexible arm/nozzle
- Enclosures
- Cabinets

4.2. General guidelines for a successful installation

Laser marking/coding used as an example in the following sections and images.

- Keep duct run length to a minimum.
- Avoid sharp bends/turns in the ductwork.
- Avoid multiple bends/turns in the ductwork.
- Use a larger diameter duct where able.
- Position the capture device as close as possible to the marking point (if used on high-speed lines, position the capture device slightly downstream).

4.3. Flexible arm and nozzle extraction

- Stay put arm should be mounted as close as possible to the marking point using the clips provided.
- Unscrew the push-fit connector from the other side of the flexible hose.
- Cut the flexible hose to suit the distance back to the extraction system connection and push onto the system inlet.

Purge air should be kept to a minimum, where possible, to prevent the fume being blown away from the nozzle. High-speed lines may need bigger scoops or nozzles both sides of the product because of the turbulence caused by the speed of the product (e.g., bottling lines).

4.4. Moving products

For applications where the product is moving past the stationary marking point head, the capture nozzle should be positioned as close as possible to the marking area on the side the product is moving towards.

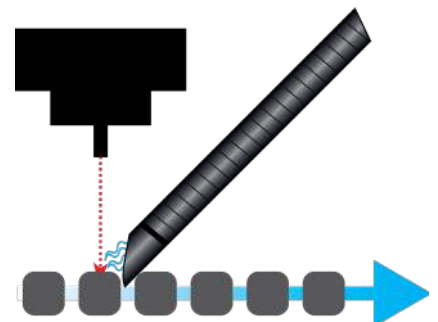

4.5. Enclosures

The extraction hose and nozzle can be attached to the enclosure surrounding the marking zone provided that the extraction point is within 1.96"-2.95" (50-75 mm) of the marking point.

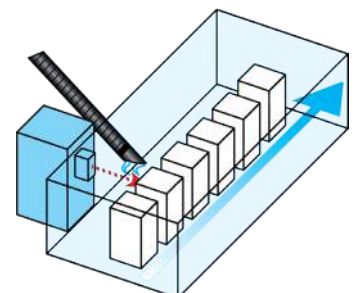

4.6. Cabinets

Cabinets normally have a 2.95" (75 mm) or 3.93" (100 mm) spigot for fume extraction. For best performance, use the same diameter hose as the spigot and reduce at the extraction system end if necessary. **Keep the hose run as short as possible.**

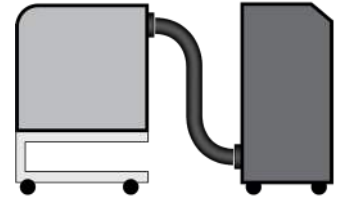

4.7. Connection to extraction system

All ductwork should be installed and connected to the extraction system before it is turned on.

4.8. Exhausting filtered air outside

This extraction system has a reversible exhaust box fitted. This provides a connection point for exhaust pipework to be fitted. It is important to keep any ducting to a minimum, to reduce back pressure within the system.

4.8.1. Exhaust box - vent to air to spigot

If the exhaust box is fitted as shown below then the fumes will vent to air from the bottom of the exhaust box. To remove and configure as an exhaust spigot follow the procedure detailed below.

1. Isolate the supply from the extraction system.
2. Using an Allen key undo and remove the 10 M5 hex socket button head screws and fiber washers that fix the exhaust box to the rear of the extraction system.
3. Turn the exhaust box over so that the exhaust spigot is facing outwards.
4. Refit the 10 M5 hex socket button head screws and fiber washers and tighten until secure.
5. Re-connect the mains supply.

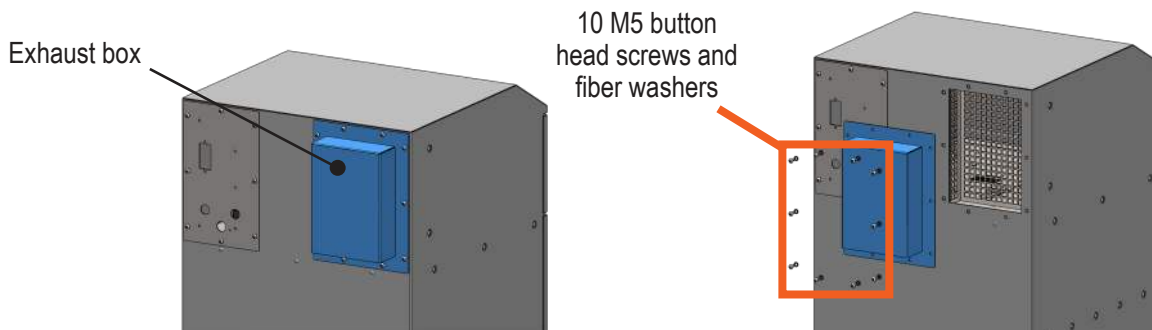

4.8.2. Exhaust box - spigot to vent to air

If the exhaust box is fitted with the spigot facing outwards (as shown below) then a hose can be connected to the spigot to vent the exhaust fumes to wherever you want to in or out of the building. To remove and configure as an exhaust box - vent to air, follow the procedure detailed below.

1. Isolate the supply from the extraction system.
2. Using an Allen key undo and remove the 10 M5 hex socket button head screws and fiber washers that fix the exhaust box to the rear of the extraction system.
3. Turn the exhaust box over so that the exhaust spigot is facing inwards.
4. Refit the 10 M5 hex socket button head screws and fiber washers and tighten until secure.
5. Re-connect the mains supply.

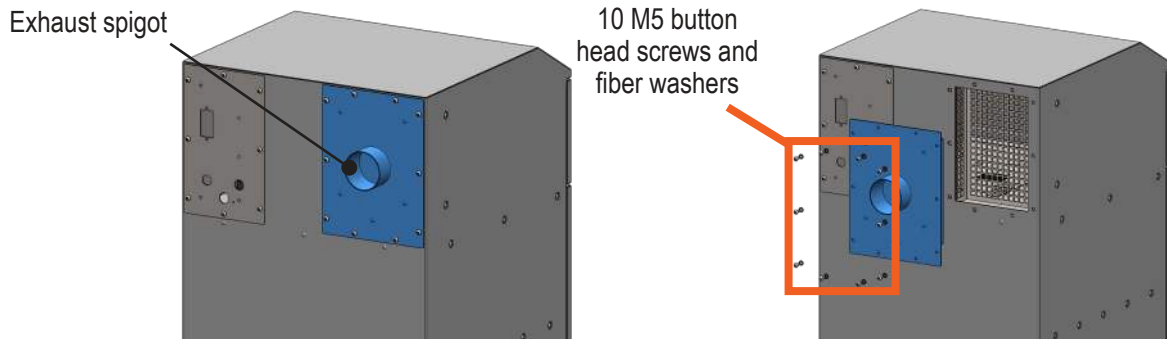

4.9. Connectivity (optional)

The Pro OS model features connectivity via an RJ45 port which is located on the rear of the extraction system. This port can be used as 2-way communication, enabling the control of the system as well as live data streaming from the extraction system. For information on how to configure your device to communicate with Pro OS, please use document:

SG-PRO OS CONNECT PROTOCOL CONFIGURATION GUIDE-BOFA-US

4.10. Connection to power supply

Please follow the specification at the rear of the manual when selecting the power supply outlet for the system. Ensure the power supply is suitable before connecting the system.

	<p>ELECTRICAL DANGER</p>	<p>Check the integrity of the electrical power cable. If the supply cord is damaged, the extraction system should not be connected to the mains. The supply cord should only be replaced by a Donaldson BOFA engineer as an electrical safety test may be required after replacement.</p>
	<p>CAUTION</p>	<p>The system MUST be connected to a properly earthed outlet.</p>

Important - 3 phase systems only: It is very important to ensure that the neutral connection is connected before turning the system on. Failure to do this may result in damage to the extraction system.

If your system was customized for your order, please read the optional features section before the power connection is made as additional connections may be required before power is connected to the extraction system.

Connect the power cable to an isolated electrical supply.

The mains socket should be installed near the extraction system. It should be easily accessible and able to be switched on/off. The cable run must be arranged to prevent trip hazard.

This equipment shall be mounted in accordance with local regulations.

The power supply which is used to provide the 12-24 VDC signal options (see section 4.10) must be protected by double insulation from mains voltage.

Portable appliance testing guidance

This appliance is a Class I electrical product that requires earth protection. The appliance contains Type 3 SPDs (surge protection devices). During PAT Testing, test voltage L-E and N-E must be limited to 250 VDC to avoid engaging the surge protection.

4.11. Remote stop/start signal (standard)

Enables the extraction system to be remotely turned on/off via an external signal.

Note: Care must be taken to ensure that the system is correctly wired in order for the extraction system to function correctly.

This configuration requires the black and red cores of the signal cable (refer to section 1 for location) to be connected to a 12-24 VDC signal. The external power supply must be protected by double insulation from mains power.

The operating voltage for this signal is between 12 and 24 VDC. Only voltages within this range should be connected. Voltages connected outside of this range may cause irreversible damage to the internal control PCB.

Red cable = +V (12 V to 24 V range)

Black cable = 0 V

When the extraction system is provided with the correct DC voltage, the blower will start and maintain the set flow rate. When the DC voltage is removed, the blower will slow down and come to a stop.

The extraction system will need to be turned on and be out of standby mode in order for this feature to operate.

4.12. System OK signal (standard)

When the filters become blocked or the extraction system develops a fault (refer to troubleshooting section), the connection between the green and white cables will become "open".

When the extraction system is running normally, the connection between the green and white cables will become "closed".

This feature will not directly stop the extraction system from running correctly, but if fitted, this feature should be terminated correctly before power is applied to the system.

Connection specification

This signal is available via the green and white cores of the signal cable. The system will provide an open/closed signal that can be connected to an external interface, beacon, or warning device following the specification below.

- **Maximum input voltage: 24 VAC**
- **Maximum current load: 3 AAC**

OR

- **Maximum input voltage: 24 VDC**
- **Maximum input load: 3 ADC**

The external power supply must be protected by double insulation from mains power.

5 Operation

5.1. Turning extraction system on

Use the mains switch on the rear of the extraction system to power up the extraction system. The screen will now illuminate.

It is recommended that the rear on/off switch is left in the on position and the touchscreen is used to stop and start the blower (if the interface is not already controlling it).

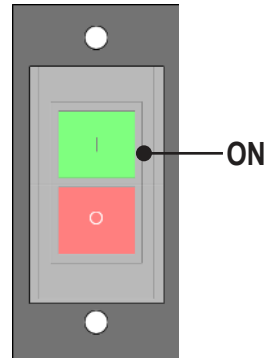

5.2. Power on cycle

Once the extraction system has been turned on, the below sequence will appear on the screen.

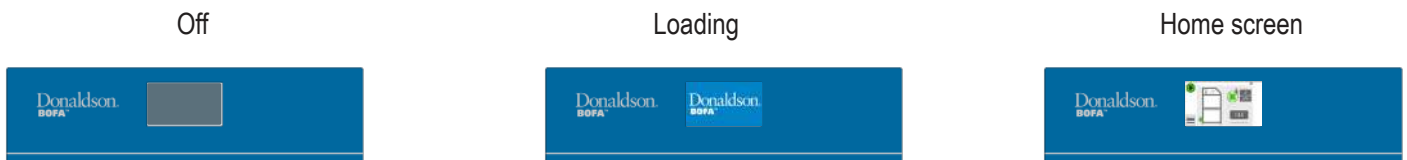

5.3. Accessing the menu and first time operation

During first time installation, it is recommended that you go to the “Settings” screen via the “Menu” screen to set up the extraction system as required.

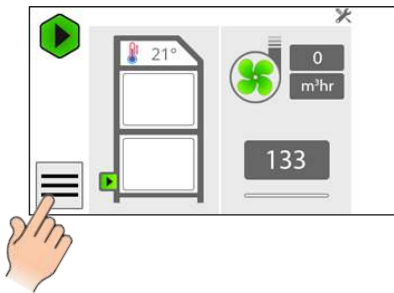

5.4. Settings

The settings feature has three programmable parameters:

1. Display units
2. Autorun
3. Language

To access the settings, follow the icons below:

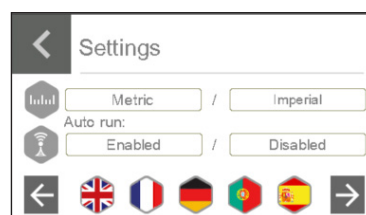
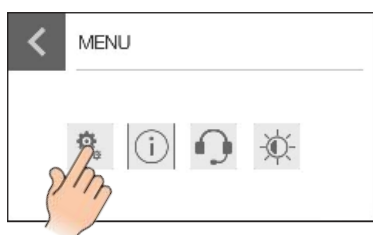

5.4.1. Changing the display systems

The airflow and temperature readings can be displayed in two ways.

1. Temperature displayed as °C - Airflow displayed as m³/h on the metric setting (default)

OR

2. Temperature displayed as °F - Airflow displayed as CFM on the imperial setting

5.4.2. Enabling the autorun feature

Autorun ON: Extraction system will require external start signal as explained in section 4.10.

Autorun OFF: Extraction system can be manually started using the “Play” button on the main screen.

5.4.3. Changing the language

The system has twenty one programmable languages. Once the language has been selected it will automatically change the system, no restarts are necessary.

English (Default)	Danish
Spanish	Czech
French	Croatian
German	Korean
Portuguese	Japanese
Hungarian	Polish
Indonesian	Italian
Swedish	Dutch
Thai	Simplified Chinese
Russian	Norwegian
Arabic	

5.5. Information

- PCB Serial number
- Software version
- Logging information

To access the “Information” screen, press the information icon:

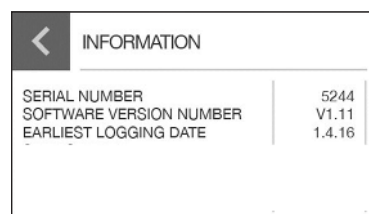
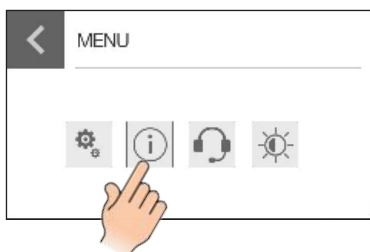

5.6. Support

The “Support” screen will display contact information for technical and sales support. To access the “Support” screen, see the following icons:

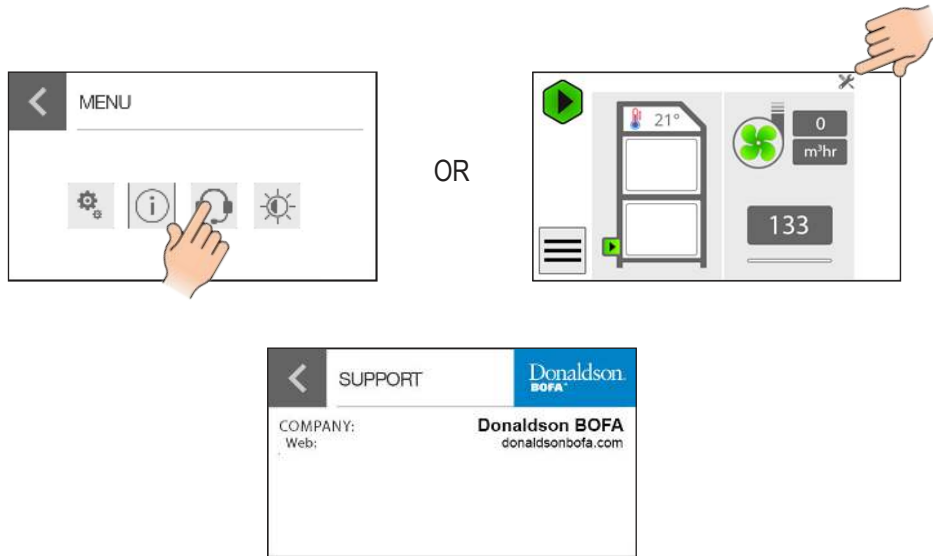

5.7. Brightness

Selecting the brightness icon allows the user to configure the brightness of the display.

The brightness can be adjusted by pressing - or + to decrease/increase brightness of the display.

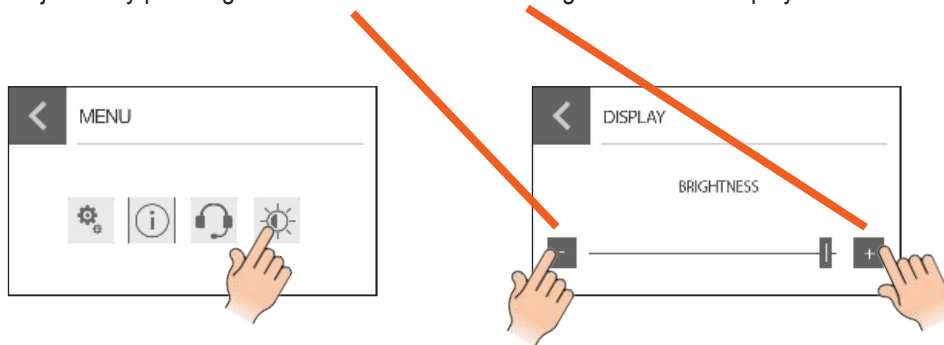

5.8. Functional test

During first-time operation, it is recommended to complete a functional test to ensure the safety elements of the fume extraction system and prevent the laser machinery from operating if a fault has occurred or there has been an issue with the initial setup.

To simulate a fault, rotate the combined filter lever 180° anti-clockwise, this will lower the combined filter, which, in turn, will activate the combined filter missing alarm.



5.9. Run control

Run control enters the system into 1 of 2 states:

1. Off: System idle
2. Running: Blower active

The “Run control” button will change its appearance according to its usage based on the system operation mode.

5.9.1. Off state

In the “Off state”, the blower is inactive and the “Run control” button will act as a “Start” button. The USB upload/download function is available (disabled in all other states).

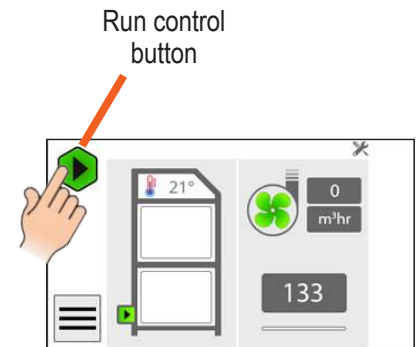

5.9.2. Running state

When “Running”, the blower will be activated and the “Run control” acts as a “Stop” button.

The “Setpoint level indicator” gives a visual indication of target setpoint level relative to maximum achievable level.

Note: If the extraction system has the autorun setting enabled, the “Run control” button will be grayed out and the blower will be controlled via the interface cable. The extraction system can only be turned off manually once the autorun feature has been turned off.

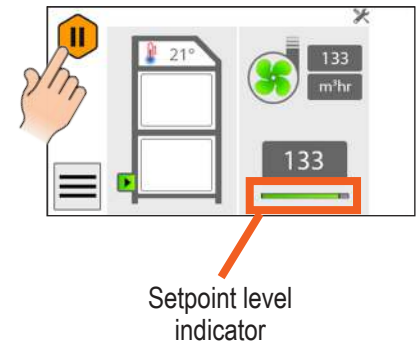

5.10. Setting the desired airflow

The system features automatic flow control. This enables the user to set the required airflow rate, then over time, as the filters begin to block, the blower will automatically begin to increase in speed to compensate for any loss in performance caused by the added restriction of the partially blocked filters.

	IMPORTANT (refer to manual)	The extraction system and all pipework must be fully installed and connected before the airflow is set.
--	---------------------------------------	---

5.10.1. To set the airflow

The airflow can be set between 59-217 cfm (100-370 m³/h).

1. Press the “Airflow set point” button (refer to diagram below for button location).
2. The screen displayed has a numeric keypad. The numbers enabled depend on the flow limits of the system. The system has flow limits 100-370. Upon entry, only numbers 1-3 will be enabled. If the user enters 5 then zero will be enabled. This will ensure that only an achievable flow setpoint can be entered.
3. Once you have entered a valid airflow, the “Enter” button will be enabled. Pressing “Enter” will save the entered setpoint and return the display to the “Main” screen. Once you have achieved your desired flow rate, release the controls. After approximately ten seconds, the flashing buttons will remain illuminated constantly to confirm that the flow rate has been stored.

The set flow rate will now be maintained throughout the life of the filter. When the extraction system can no longer maintain the set flow rate, an alarm will sound and the display will indicate which filter should be changed.

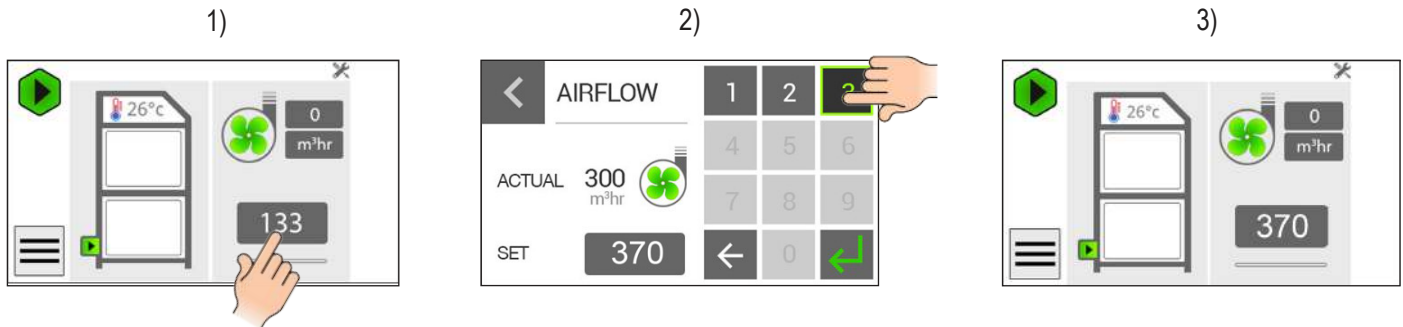

5.11. System status of filters and blower

5.11.1. Filter blockage level indication

The “Filter” icons will fill relative to their blocked value. The “Filter” icons color represent their health, refer to maintenance section for replacement procedure:

Icon	Color	Filter status
1.	Green	Less than 75% blocked.
2.	Amber	Greater than 75% blocked.
3.	Red	Fully blocked.

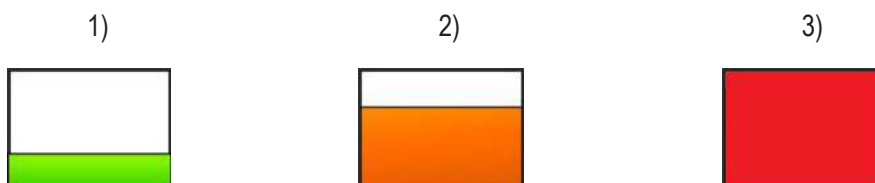

5.11.2. Filter not installed correctly warning

The “Filter status” icon is replaced by a “Warning triangle” icon to indicate that a missing filter has been detected:



Note: This extraction system only has a sensor for the combined filter.

5.11.3. Inlet status

The “Inlet status” icon gives visual feedback on the state of the inlet duct:

Icon	Color	Inlet icon status
	Green	OK.
	Amber	Warning: High vacuum on pipework.
	Red	Fault: Blockage.

If the amber or red icon appear, inspect the hose kit and installation (refer to maintenance section). Reduce the restriction causing the high vacuum or blockage.

When the above “Inlet status” icon is pressed the “System information” screen as shown here is displayed.

The differential pressure across each section of the system is displayed. A system overview bar graph is displayed to easily visualize the pressures across the system.

- Inlet pressure
- Pre-filter pressure
- Combined filter pressure
- Total system pressure
- Free: Available head pressure for system at current airflow

Each section has a red, amber or green warning icon indicating the health of the section.

The “Blower status” icon is displayed on numerous screens. Clicking the icon will navigate to the “Blower diagnostics” screen.

5.11.4. Blower diagnostics

Each connected blower is accessible from this screen. The blower selection bar is populated with the number of blowers connected to the system. The screen displays the following blower data:

- RPM: speed
- Head: pressure: (Pa)
- Drive: voltage or PWM (blower dependent)

The blower selection icons will display red if an error has been detected with the associated blower.

The “Back” button navigates the user back to the previous screen.

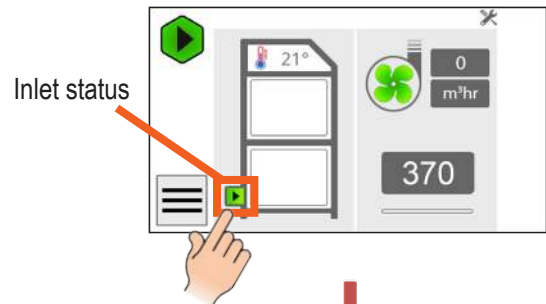

System information screen

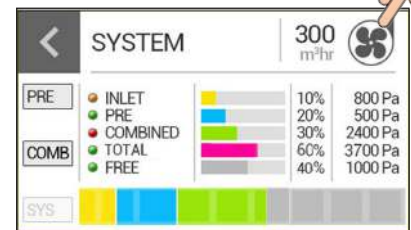

Home screen

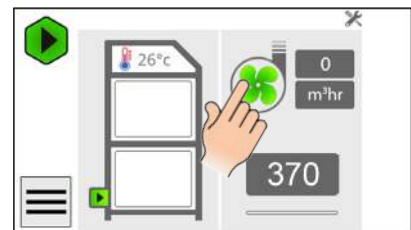

Blower diagnostics screen

back button

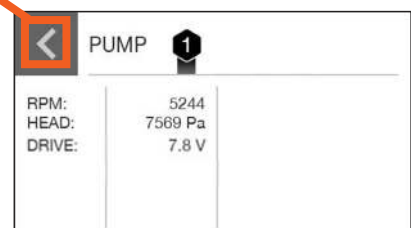

5.11.5. Filter status

The “Combined” and “Pre-filter” screens hold all the data relevant to the state of the combined and pre-filter.

- Part number: Part number of required filter
- Block: Filter block level relative to achievable system pressure (%)
- Pressure: Differential pressure across filter (Pa)

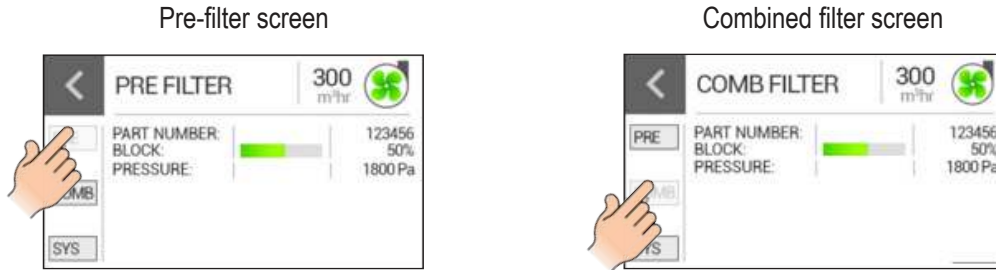

5.11.6. System temperature

The system has an internally mounted thermal trip that detects the temperature in the filter compartment. If the temperature rises above 131 °F (55°C), the extraction system will automatically shut down the blower and display the symbol shown here.

If this symbol is displayed, the extraction system should be totally isolated from the mains supply and the extraction system should be fully inspected for evidence of the temperature rise (including inside the pre-filter).

Once the extraction system is safe to turn back on and the internal temperature has dropped below 122 °F (50°C), the thermal trip can be reset. To do this, follow the procedure below:

1. Isolate the supply from the extraction system.
2. Open the front door and remove the combined filter.
3. Locate the circular cut out in the shelf, at the front of the extraction system.
4. Inside the cut out there is a small red button that can now be pressed back in.
5. Re-fit the combined filter, close the front door and re-connect the mains supply.

The extraction system internal temperature is displayed on the screen in the following formats:

- Temperature: less than 140 °F (60°C) (gray)
- Temperature: greater than 140 °F (60°C) alarm

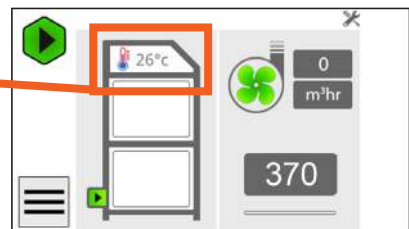
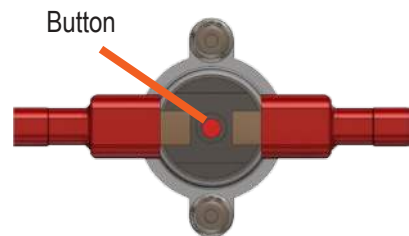
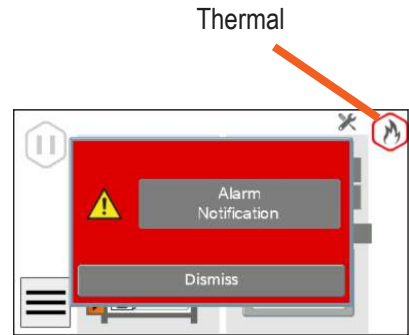

If the temperature exceeds the alarm threshold, the “Alarm” icon shown below is displayed to draw attention to the user. If this temperature reaches 140 °F (60°C), the blower will shut down and will not restart until the temperature is below 140 °F (60°C) and the system has been reset.

6 Maintenance

6.1 Maintenance UK

It is a legal requirement, under regulation 9 of the COSHH regulations that all local exhaust ventilation systems are thoroughly examined and tested at least once every 14 months (typically carried out annually). The approved code of practice recommends that a visual check should be carried out at least once a week.

COSHH requires the annual inspection and testing to be carried out by a competent person and specifies that documentation results are recorded in a log.

Contact the seller for more information about inspection and certification.

6.2 Maintenance general

User maintenance is limited to cleaning the system and filter replacement, only the manufacturer's trained maintenance technicians are authorized to carry out component testing and replacement. Unauthorized work or the use of unauthorized replacement filters may result in a potentially dangerous situation and/or damage to the extraction system and will invalidate the manufacturer's warranty.

6.2.1 Cleaning the extraction system

Stainless steel extraction systems should be cleaned with a non-acidic proprietary stainless steel cleaner, in accordance with the manufacturer's user instructions.

The powder-coated finish can be cleaned with a damp cloth and non-aggressive detergent, do not use an abrasive cleaning product as this will damage the finish.

The cooling inlets and outlets should be cleaned once a year to prevent build-up of dust and overheating of the extraction system.

6.3 Replacing filters

The Pro OS system constantly monitors the condition of the filter. As the filter blocks, the Pro OS display will show the relevant filter symbol filling up (see section 5.11 for screen details).

It is recommended to replace filters every 12 months, unless the system prompts for more frequent changes. Users should maintain a record of these replacements.

The filter requires attention when the display shows the filter blocked icon/filter output signal alarms or when the extraction system no longer removes fume efficiently.

It is recommended that a spare set of filters are kept on-site to avoid prolonged extraction system unavailability. Part numbers for replacement filters can be found on the filters fitted in your system.

To prevent overheating, extraction systems should not be run with a blocked filter condition, or with dust obstruction of inlets/outlets.

6.3.1. Pre-filter replacement

Refer to section 2.2 for PPE requirements.

To remove and replace the pre-filter, follow the procedure detailed below.

1. Isolate the electrical supply to the extraction system.
2. Undo the latches on the front of the extraction system and open the door.
3. The pre-filter is the lower of the two filters. Using the handle on the front of the filter, pull it out of the extraction system.
Important: the handle must only be used for the purpose of pulling out the filter.
4. Once removed, it is recommended that the used filters are bagged and sealed.
5. Slide in the new filter, ensuring it is fully pushed in and positioned correctly on the spigot in the back of the extraction system.
6. Close the door and fasten the two latches.



6.3.2. Combined filter replacement

To remove and replace the combined filter, follow the procedure detailed below.

1. Isolate the electrical supply to the extraction system.
2. Undo the latches on the front of the extraction system and open the door.
3. The combined filter is the higher of the two filters. Rotate the lever below the filter through 180° to lower the combined filter.
4. Using the handle on the front of the filter, pull it out of the system being careful to support it as it comes free as it is heavy.
Important: the handle must only be used for the purpose of pulling out the filter.
5. Once removed, it is recommended that the used filters are bagged and sealed.
6. Slide in the new filter, ensuring it is fully pushed in and positioned correctly.
7. Rotate the lever back through 180° to raise the filter into position.
8. Close the door and fasten the two latches.
9. Reconnect the power supply.



Both filters **MUST** be fitted when the extraction system is in use. If the combined filter is not installed correctly, the Pro OS system will not allow the blower to operate.

7 System display

7.1. USB connectivity

For both download and upload connectivity, the system must be on before inserting the USB drive. Once on, Pro OS will allow data to be uploaded or downloaded to/from the system:

Upload

- Configuration files (supplied by Donaldson BOFA)
- Software updates (supplied by Donaldson BOFA)

Download

- System data file

Pro OS will allow the user to choose between uploading or downloading data. If no upload data is detected to install, Pro OS will only allow the user to download:



7.1.1. USB lock

If enabled, the touch panel will display a PIN entry screen when a USB stick is inserted into the extraction system. Once the correct PIN is entered, the normal upload/download screen will be displayed.

The PIN for this will be pre-configured with Donaldson BOFA prior to ordering the extraction system.

If this feature is required, please contact your local representative who will be able to assist with your request.

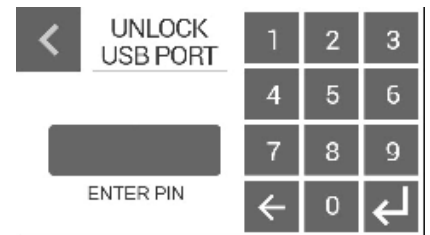

7.1.2. Upload/download

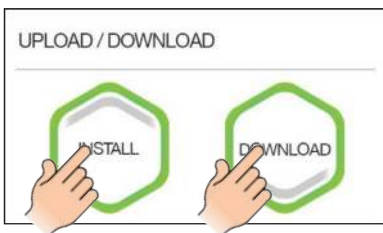

Both options available

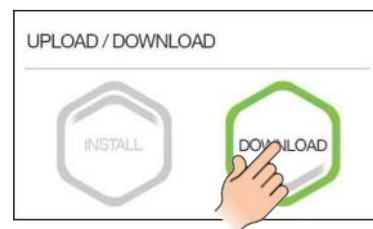

No data detected - "Download" available

If the user selects "Install" in the "Upload/download" selection screen, they will be navigated to the "Upload" screen. There are two types of upload available:

- Configuration Data: Configuration parameters for extraction system
- Software: Software update file

Pro OS will read the data on the attached memory stick and enable the file choice icon if a corresponding file is discovered:

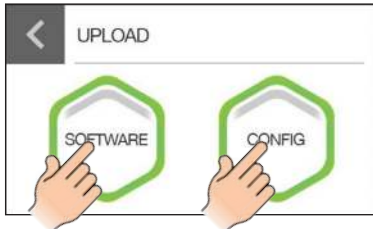

"Upload" screen – software and config file detected

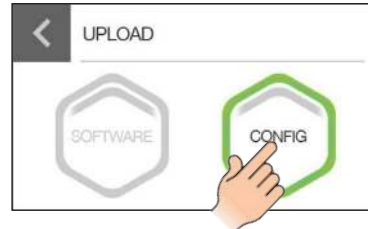

"Upload" screen – only config file detected

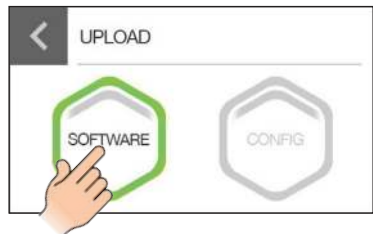

"Upload" screen – only software file detected

Once the user has selected their required action, the system will ask them to confirm:

- No: Navigates the user to the previous screen.
- Yes: Commence with selected action.

Once the action has been confirmed, the system will commence. A progress bar and numeric reading gives the user feedback of the state of the transaction:

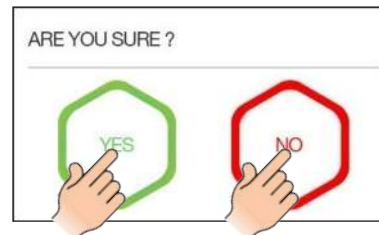

"Confirmation" screen

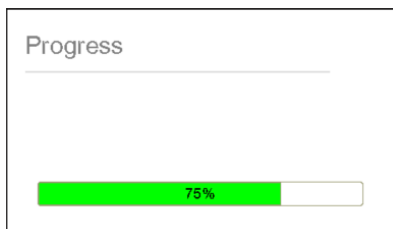

"Progress" screen - transaction in progress

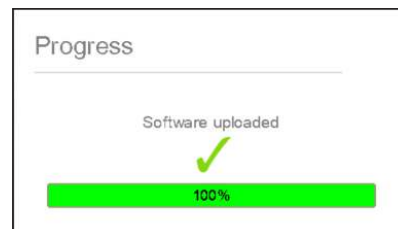

"Progress" screen - transaction successfully completed

Once the action has been completed, the system is required to restart.

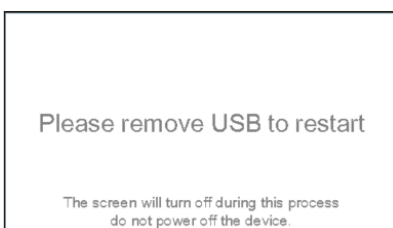

"Restart" screen

8 Troubleshooting

8.1. Fault indication

In the unlikely event of a problem with the extraction system, please contact your local representative.

8.2. System alarms

The “Alarm notification” bar will populate with alarms when triggered. The alarm icons populate from top to bottom, pushing older alarms down (most important alarms will stay at the top). The alarms will clear once resolved. The bar can display up to five alarms at a time. If more alarms are triggered, selecting one of the alarm icons will navigate to the “Alarms” screen where all active alarms can be seen.

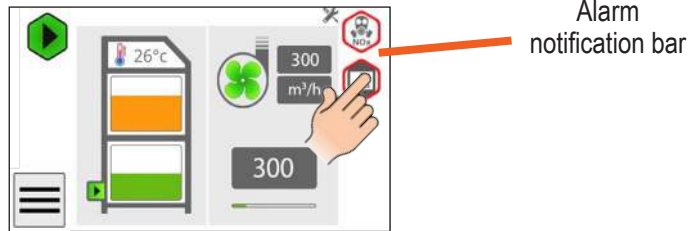
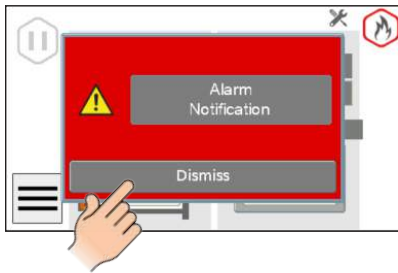

Pressing the relevant alarm button will provide more information.

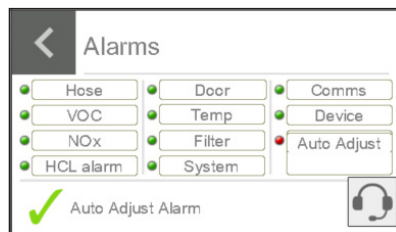
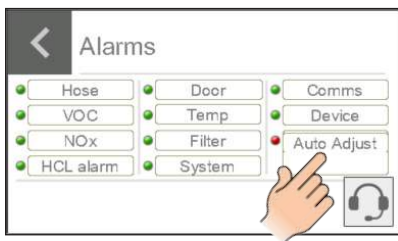

Activated alarms are shown in red. The standard alarms that the system will indicate are shown in the table below, others are relevant only when that option is included:

Alarm icon	Function
	Thermal
	Hose blocked
	Combined filter not fitted correctly
	Pro OS board overheating
	System fault
	VOC

8.2.1. Thermal

If the system detects an internal temperature greater than 131 °F (55°C), it will automatically shut down the extraction system to prevent damage to components within the extraction system. Once the internal temperature has dropped by 122 °F (50°C), the extraction system will be able to restart. To restart the extraction system after an over temperature alarm, the extraction system reset button on the thermal trip needs to be pressed (refer to section 5.11.6).

8.2.2. Hose blocked

This alarm is triggered when the system detects a full blockage in the installation. The system interprets a full blockage as a vacuum spike within the ductwork, indicating that the extraction system cannot maintain the set airflow due to the blockage.

During this time, it is normal to hear the blower increase in speed. The blockage will need to remain in the ductwork for over 5 seconds to trigger the alarm.

To remove the blockage, isolate the extraction system from the mains, remove the flexible hose, locate and remove the blockage then reattach the hose as previously installed.

8.2.3. Combined filter not fitted correctly

If the combined filter has not been inserted correctly, the symbol will be displayed. Once the combined filter has been inserted correctly, the alarm will clear. For combined filter replacement, see section 6.3.

8.2.4. Pro OS board overheating

The Pro OS board is fitted with thermal protection to prevent any of the components being damaged at high temperatures. This is set to 149 °F (65°C). Once the internal temperature has dropped below 140 °F (60°C), the extraction system will be able to restart.

8.2.5. System fault

The system fault alarm will be shown if there is a fault with any of the following alarms:

- Hose blocked
- Pre-filter full
- Combined filter full
- Auto adjust

8.2.6. VOC sensor

The VOC sensor constantly monitors the exhaust gas of the extraction system.

If the VOC level in the exhaust exceeds the PPM (parts per million) level pre-set at Donaldson BOFA, the carbon within the filter is saturated and this will trigger the gas alarm and display the gas icon.

Removing the gas alarm warning

At this point, the extraction system should be isolated from the mains, and a new combined filter fitted. Once a new filter is installed, the alarm will clear.

8.2.7. Auto adjust

When first setting the airflow on your new extraction system, Pro OS will detect if the desired airflow is achievable with the system as configured during installation. If the installation is causing too much restriction for the desired airflow to be reached, the auto adjust feature will be activated:

1. The "Airflow setpoint" box will begin flashing red.
2. The actual airflow visual will drop to display the highest airflow that can be achieved.
3. The airflow will stabilize and red box and system fault icon will clear.



8.3. Blower fault

If a fault was to occur on the blower installed in the system, the blower icon will turn red and the extraction system will shut down. If the red icon is pressed, the system will navigate to the blower diagnostic screen.

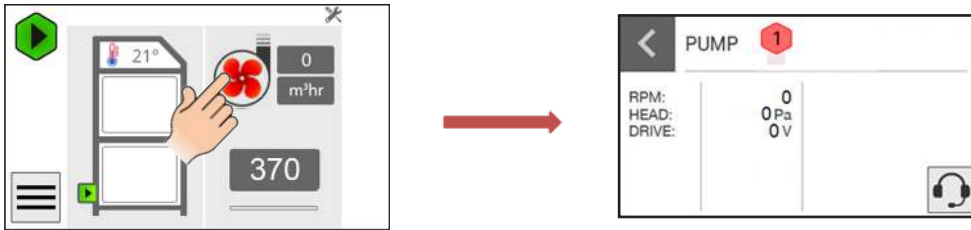

9 Replacement parts

9.1. Consumable spares

The extraction system contains a pre-filter and a combined filter. These should be replaced when instructed to do so by the Pro OS system (see maintenance section for replacing filters), when the extraction system is not performing efficiently, or at least once every 12 months.

To maintain performance, it is important that the filters are replaced with identical Donaldson BOFA filters. To reorder, please refer to the filter number printed on the filter installed in your extraction system. See part numbers below:

1. **1UA1030156 (pre-filter)**
2. **1UA1030155 (combined filter)**

9.2. Maintenance protocol

The Donaldson BOFA data logging function enables the retrieval of filter change intervals. Users may also wish to record changes in the table below.

Extraction System Serial Number:			
Pre-filter (1UA1030156)		Combined filter (1UA1030155)	
Date	Engineer	Date	Engineer

9.3. Filter disposal

The pre-filter and combined filter are manufactured from non-toxic materials. Filters are not reusable, cleaning used filters is not recommended. The method of disposal of the used filters depends on the material deposited on them.

For your guidance:

Deposit	EWC* Listing	Comment
Non-hazardous	15 02 03	Can be disposed of as non-hazardous waste.
Hazardous	15 02 02M	The type of hazard needs to be identified and the associated risks defined. The thresholds for these risks can then be compared with the amount of material in the filters to see if they fall into the hazardous category. If so, the filters will need to be disposed of in line with the local/national regulations.

*European Waste Catalogue

10 System specifications

Extraction system: **AD Oracle Pro OS Connect**

Flowrate minimum: 59 cfm (100 m³/h)

Flowrate maximum: 217 cfm (370 m³/h) @ 230 V and 115,
206 cfm (350 m³/h) @ 100 V

Weight: 157 lbs (71 kg)

Airflow measuring system: Windvane

Suction pressure: 96 mBar

Blower: Centrifugal fan

Output: 1.2 kW

Noise level: Below 80 dB(A) (at typical operating speed)

Maximum altitude: 2000 m

Electrical supply: 100-230 V (+/-10%)

Hertz: 50/60 Hz

Full load Current: 12.5 A

No. of phases: 1

Ethernet: RJ45

Indoor use only

Overvoltage category II

Pollution degree 2

Not for use in wet applications

Environmental operating range:

Temperature: +41 °F (5°C) to + 104 °F (40°C)

Humidity: Max 80% RH up to 87.8 °F (31°C)

Max 50% RH at 104 °F (40°C)

Process fume/gas entering this system should be within the above temperature range.

Wiring schematic and spare parts list available upon request.

Size:

	Imperial (inches)	Metric (mm)
Height	39.2	995
Width	21.5	547
Depth	24.6	626

Filters:

Filter type	Surface area	Efficiency
Pre-filter	129.1 sq ft (12 m ²)	F8 ePM1 @ 70%
Combined filter	32.3 sq ft (3 m ²)	99.995% @ 0.3 microns

Combined filter (gas section):

Filter type	Carbon type	Volume
Combined filter (gas)	Activated carbon	18.8 liters

11 Contact information

Donaldson BOFA head office – UK & ROW:

19-20 Balena Close
Creekmoor Industrial Estate
Poole
Dorset
BH17 7DU
United Kingdom

Tel. +44 (0) 1202 699 444
Email: bofasales@donaldson.com

Donaldson BOFA German office:

Email: bofavertrieb@donaldson.com

Donaldson BOFA US office:

303 S Madison Street
Stanton, Illinois
62088 USA

Tel. +1 (618) 205 5007
Email: bofasalesus@donaldson.com

12 Inspection record



Donaldson
BOFA™

Inspection Record

Local Exhaust Ventilation System

Health & Safety at Work Act 1974 - Control of Substances Hazardous to Health - Regulation 9 (2002) Thorough Examination and Testing of Local Exhaust Ventilation Systems

Company:	System Designation:	System Installation Date:
Designated Person:		

Inspection and Maintenance Schedules

1. Daily checks.
2. Weekly inspection of process enclosure, extract offtake, hose/ducting, and extraction system.
3. Monthly inspection of process enclosure, extract offtake, hose/ducting, and extraction system.
4. Yearly inspection/testing.

Process enclosure, extract offtake(s), hose/ducting, and extraction system.

Inspection and Maintenance Record

1. Daily inspection

Inspection of the process to ensure extract devices/nozzles/enclosures/hoses are in place and correctly positioned. Examination of the extraction system to ensure it is running. This to be carried out by the operator. Daily inspection not recorded.

2. Weekly inspection

Weekly inspection by supervisor of physical condition of extract devices/nozzles/enclosures/hoses and extraction system for damage, change (parts added or removed) and correct operation, etc. Check also that daily inspections have been completed. Tick boxes to confirm system ok/change. Add details of any changes.

Report changes to Engineering Manager. Record any remedial actions taken.

Week number	Date	System ok	System change	Details of change/repairs, etc.	Initial
1					
2					
3					
4					
5					
6					
7					
8					
9					
10					
11					
12					
13					
14					
15					
16					
17					
18					
19					
20					
21					
22					
23					
24					
25					

Weekly inspection by supervisor of physical condition of extract devices/nozzles/enclosures/hoses and extraction system for damage, change (parts added or removed) and correct operation, etc. Check also that daily inspections have been completed. Tick boxes to confirm system ok/change. Add details of any changes.

Report changes to Engineering Manager. Record any remedial actions taken.

Week number	Date	System ok	System change	Details of change/repairs, etc.	Initial
26					
27					
28					
29					
30					
31					
32					
33					
34					
35					
36					
37					
38					
39					
40					
41					
42					
43					
44					
45					
46					
47					
48					
49					
50					
51					
52					

Process enclosure, extract offtake(s), hose/ducting, and extraction system.

Inspection and Maintenance Record

3. Monthly inspection

In addition to weekly checks, disconnect hoses and check for blockage and smooth operation of fan, signs of dust or vapor/gas/odor carry over. Tick boxes to confirm system ok/change. Add details of any changes. Report changes to Engineering Manager. Record any remedial actions taken.

Week number	Date	System ok	System change	Details of change/repairs, etc.	Initial
1					
2					
3					
4					
5					
6					
7					
8					
9					
10					
11					
12					

4. Yearly inspection

	Comments	Supervisor signature:	Date:
Annual service to include all regular checks, inspection of filter condition, blower, and electrical system, and a filter replacement (if not changed within the previous 12 months).			
Annual thorough inspection and testing of LEV system in accordance with C.O.S.H.H. regulation 9 (max interval 14 months) including reporting.			