

AD Nano+

Fume Extraction System - Advantage Range

Datasheet

Technical Specification and Product Information

A cost-effective system for light to medium-duty applications.

The AD Nano+ is a mid-sized fume extraction system for light to medium-duty laser applications. This cost-effective solution includes many features of our larger models, making it ideal for installations with limited floor space.

FEATURES

- Low noise levels
- Small footprint
- Long-life, low-cost replacement filters

Approvals: UKCA and CE



TECHNICAL SPECIFICATION

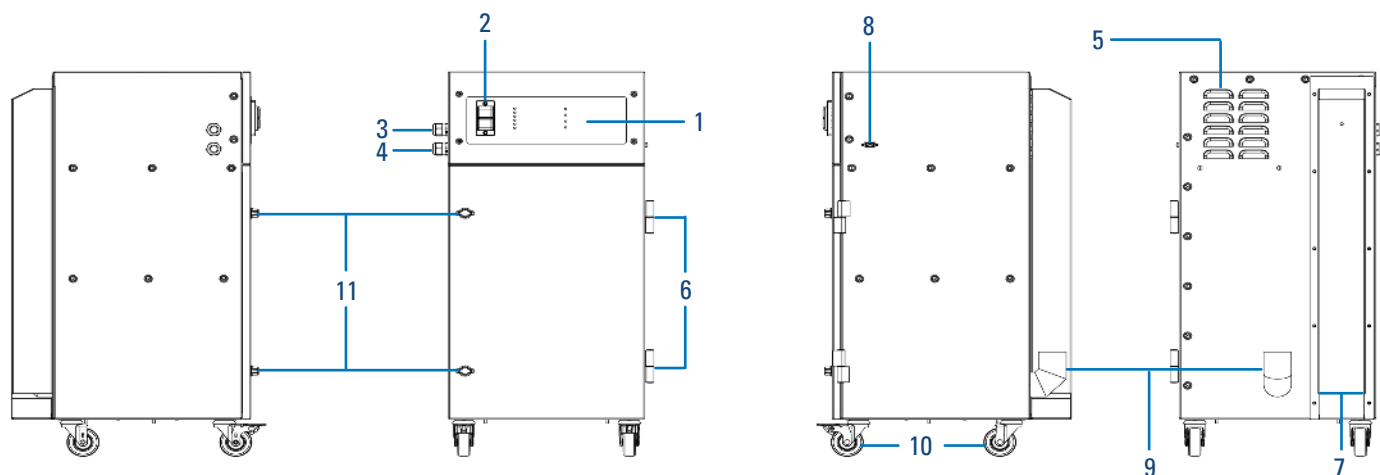

- | | | |
|---------------------------|--------------------------|---|
| 1. Control panel | 5. Blower cooling inlet | 9. Hose inlet connection - 2.0" (50 mm) |
| 2. On/off switch | 6. Door hinges | 10. Castors |
| 3. Power cable inlet | 7. Exhaust outlet | 11. Door latches |
| 4. Signal/interface cable | 8. Interfacing connector | |

TECHNICAL DATA

Voltage	Airflow		Pressure	Dimensions (H x W x D)		Weight (+/- 5%)		Noise level*	Frequency	Full load current
	cfm	m ³ /hr		in	mm	lbs	kg			
115-230	176	300	96	31.1 x 14.2 x 16.5	790 x 360 x 420	93	42	< 60	50/60	12.5

AIRFLOW

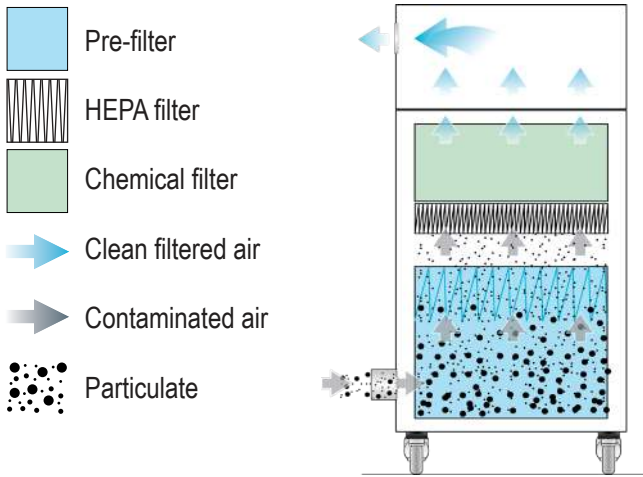

FILTER SPECIFICATIONS

Model	Surface media area (approx)		Filter efficiency
	ft ²	m ²	
DeepPleat DUO pre-filter	64.5	6	ePM1 70%
Combined filter (HEPA)	23.5	2.2	99.997% @ 0.3 microns

Model	Activated carbon volume	
	lbs	kg
Combined filter (gas)	16.5	7.5

PART NUMBERS - FILTERS

DeepPleat DUO pre-filter	Combined filter
1UA1030190	1UA1030191

PART NUMBERS - SYSTEM

Description	Part number
Powder-coated, 115-230 V No options	1U30811020-1214
Powder-coated, 115-230 V 24 V S/S and SOK	1U630811520-1214
Stainless steel, 115-230 V No options	1U30106020-1214
Stainless steel, 150-230 V 24 V S/S and SOK	1U630106020-1214-2

CUSTOMIZATIONS

Options

Power cables
Remote stop/start signal (S/S)
System OK signal (SOK)
Override (O/R)
VOC sensor

Cabinet construction

Brushed stainless steel
Powder-coated mild steel (RAL7016)

Power cables

Type B
Type E
Type G

Compatible accessories:

ILF 300
ILF 600
ILF 1000

* Noise level: At typical operating speed.

Datasheet correct at time of publishing. Where applicable, the carbon used in Donaldson BOFA systems is capable of removing a wide range of VOCs, however it is the responsibility of the user to ensure the carbon is suitable for their application. For specific applications, please contact us for details.

Important Notice

Many factors beyond the control of Donaldson can affect the use and performance of Donaldson products in a particular application, including the conditions under which the product is used. Since these factors are uniquely within the user's knowledge and control, it is essential the user evaluate the products to determine whether the product is fit for the particular purpose and suitable for the user's application. All products, product specifications, availability and data are subject to change without notice, and may vary by region or country.



Approvals: REACH and RoHS. See individual product technical data for specific accreditations.



Donaldson BOFA

UK & ROW
Tel. +44 (0) 1202 699 444
Email. bofasales@donaldson.com
Web. donaldsonbofa.com

Germany
Email. bofavertrieb@donaldson.com

USA
Tel. +1 (618) 205 5007
Email. bofasalesus@donaldson.com

ENG (December 2024) Donaldson BOFA AD Nano+ Datasheet. ©2011-2024 Donaldson Company, Inc. Donaldson, Torit, Dalumatic, Delta P, Delta P Plus, Downflo, Dura-Life, Easy Duct, PowerCore, Synteq XP, Ultra-Web, Unimaster and the color blue are marks of Donaldson Company, Inc. All other marks belong to their respective owners.