

AD 500 iQ

Fume Extraction System - Advantage Range

Datasheet

Technical Specification and Product Information

A system for medium-duty laser applications.

The AD 500 iQ fume extraction system is ideal for medium-duty applications that produce significant amounts of particulate. It offers a large filter capacity along with high airflow and pressure rates.

FEATURES

- Real-time airflow reading
- Independent filter condition monitoring
- High contrast display
- Remote diagnostics via USB
- Long-life, low-cost replacement filters

Approvals: UKCA and CE | cUL | UL*



TECHNICAL SPECIFICATION

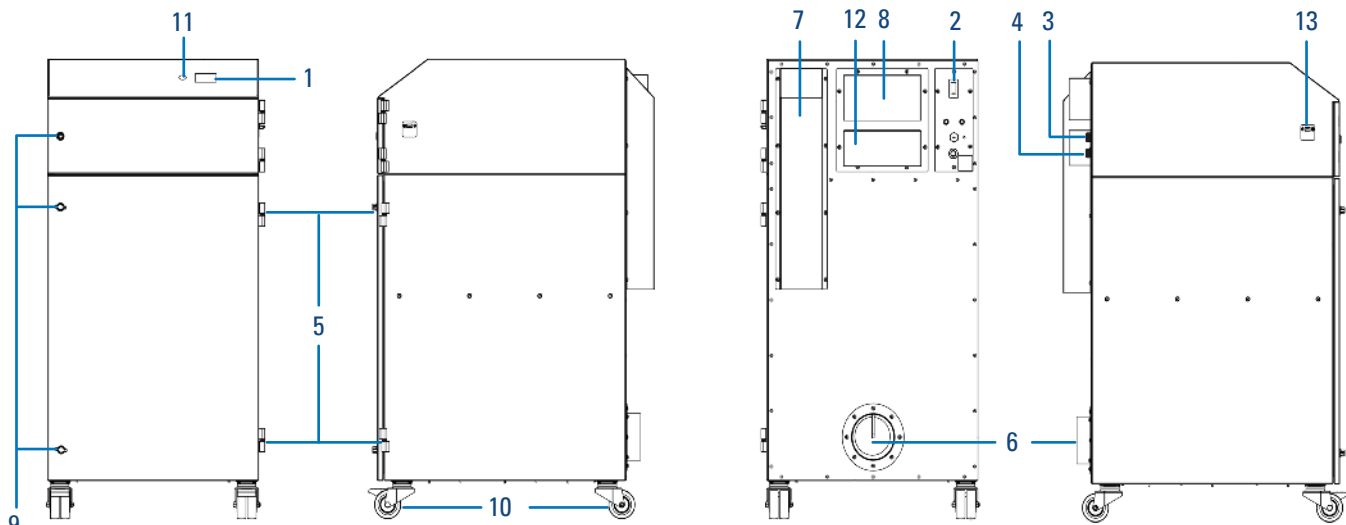

- | | | |
|---------------------------|---|---------------------------|
| 1. iQ display | 6. Hose inlet connection - 4.92" (125 mm) | 11. Standby button |
| 2. On/off switch | 7. Exhaust outlet | 12. Blower cooling outlet |
| 3. Power cable | 8. Blower cooling inlet | 13. USB port |
| 4. Signal/interface cable | 9. Door latches | |
| 5. Door hinges | 10. Castors | |

TECHNICAL DATA

Voltage	Airflow		Pressure (+/- 10%)	Dimensions (H x W x D)		Weight (+/- 5%)		Noise level**	Frequency	Full load current
	V	cfm		m ³ /hr	mbar	in	mm			
115	324	550	100	47.4 x 24.4 x 31.1	1205 x 620 x 790	292	142	< 60	50/60	14.8
230										9.5

AIRFLOW

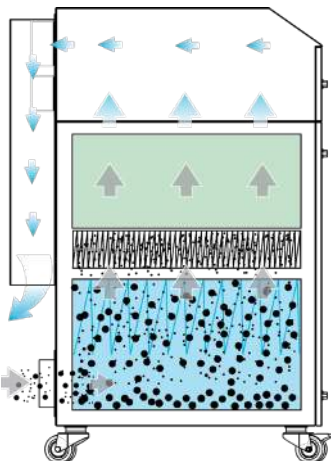
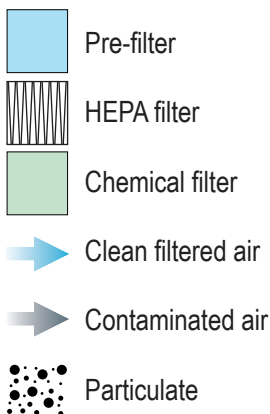

PART NUMBERS - SYSTEM

Description	Part number
Powder-coated, 230 V No options	1U30811511-1419
Powder-coated, 230 V SOK	1U630811511-1419
Powder-coated, 115 V No options	1U10810511-1419
Powder-coated, 115 V 24 V S/S, SOK and O/R	1U4660810511-1419
Stainless steel, 230 V No options	1U30106511-1419

FILTER SPECIFICATIONS

Model	Surface media area (approx)		Filter efficiency
	ft ²	m ²	
DeepPleat DUO pre-filter	322.8	30	F8 50% @ 0.3 microns
Combined filter (HEPA)	80.7	7.5	99.995% @ 0.3 microns

Model	Activated carbon volume	
	ltr	
Combined filter (gas)	53.7	

PART NUMBERS - FILTERS

DeepPleat DUO pre-filter	Combined filter
1UA1030222	1UA1030297

CUSTOMIZATIONS

Options

Power cables
Remote stop/start signal (S/S)
System OK signal (SOK)
Override (O/R)
VOC sensor
Exhaust box/exhaust spigot

Cabinet construction

Brushed stainless steel
Powder-coated mild steel (RAL7016)

Power cables

Type B
Type E
Type G
Type free ends

Compatible accessories:

Spark Arrestor 2
ILF 600

*cUL | UL: Tested to the appropriate standards, but testing may be provided by alternate nationally recognized test laboratories. Certain product configurations may affect the certification. Please speak to your sales representative.

** Noise level: At typical operating speed.

Datasheet correct at time of publishing. Where applicable, the carbon used in Donaldson BOFA systems is capable of removing a wide range of VOCs, however it is the responsibility of the user to ensure the carbon is suitable for their application. For specific applications, please contact us for details.

Important Notice

Many factors beyond the control of Donaldson can affect the use and performance of Donaldson products in a particular application, including the conditions under which the product is used. Since these factors are uniquely within the user's knowledge and control, it is essential the user evaluate the products to determine whether the product is fit for the particular purpose and suitable for the user's application. All products, product specifications, availability and data are subject to change without notice, and may vary by region or country.



Approvals: REACH and RoHS. See individual product technical data for specific accreditations.



Donaldson BOFA

UK & ROW
Tel. +44 (0) 1202 699 444
Email. bofasales@donaldson.com
Web. donaldsonbofa.com

Germany
Email. bofavertrieb@donaldson.com

USA
Tel. +1 (618) 205 5007
Email. bofasalesus@donaldson.com

ENG (March 2026) Donaldson BOFA AD 500 IQ Datasheet. ©2011-2026 Donaldson Company, Inc. Donaldson, Torit, Dalamatic, Delta P, Delta P Plus, Downflow, Dura-Life, Easy Duct, PowerCore, Synteq XP, Ultra-Web, Unimaster and the color blue are marks of Donaldson Company, Inc. All other marks belong to their respective owners.